

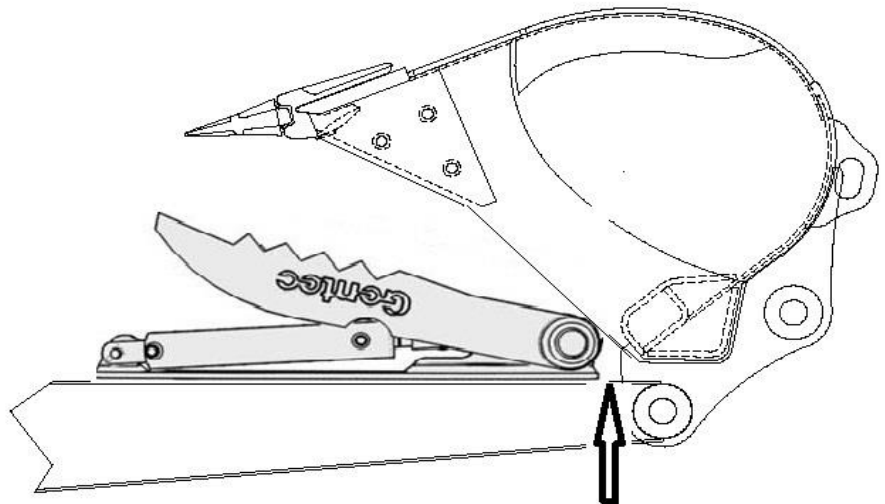

THUMB INSTALLATION INSTRUCTIONS:

- 1) Position Thumb in stowed (retracted) position as shown below
- 2) Curl bucket completely in
- 3) Slide the thumb until contact occurs with bucket, slide thumb back leaving 1" gap
- 4) Disconnect battery before welding
- 5) Clean weld area – weld completely around the bracket
- 6) Weld with #7018 rod or equivalent low hydrogen electrode
- 7) For Hydraulic thumbs set the pressure to 1800 PSI Max



In this position, 1 inch clearance between bucket and thumb

Should you require further technical support Call 1-855-533-0435
Monday to Friday 8:00 a.m. to 6:00 p.m. EST